

SECTION R303

LIGHT, VENTILATION AND HEATING

R303.1 Habitable rooms. All habitable rooms shall be provided with aggregate glazing area of not less than 8 percent of the floor area of such rooms. Natural ventilation shall be through windows, doors, louvers or other approved openings to the outdoor air. Such openings shall be provided with ready access or shall otherwise be readily controllable by the building occupants. The minimum openable area to the outdoors shall be 4 percent of the floor area being ventilated.

Exceptions:

1. The glazed areas need not be openable where the opening is not required by Section R310 and a whole-house mechanical ventilation system is installed in accordance with M1507.
2. The glazed areas need not be provided in rooms where Exception 1 above is satisfied and artificial light is provided capable of producing an average illumination of 6 foot-candles over the area of the room at a height of 30 inches above the floor level.

R303.2 Adjoining rooms. For the purpose of determining light and ventilation requirements, any room shall be considered as a portion of an adjoining room when at least one-half of the area of the common wall is open and unobstructed and provides an opening of not less than one-tenth of the floor area of the interior room but not less than 25 square feet.

R303.3 Bathrooms. Bathrooms, water closet compartments and other similar rooms shall be provided with aggregate glazing area in windows of not less than 3 square feet, one-half of which must be openable.

Exception:

1. The glazed areas shall not be required where artificial light and a local exhaust system are provided. The minimum ventilation rates shall be 50 cfm for intermittent ventilation or 20 cfm for continuous ventilation. Ventilation air from the space shall be exhausted directly to the outside.

R303.4 Mechanical Ventilation Where the air infiltration rate of a dwelling unit is less than 5 air

changes per hour when tested with a blower door at a pressure of 0.2 inch w.c. (50 Pa) in accordance with Section N1102.4.1.2, the dwelling unit shall be provided with whole-house mechanical ventilation in accordance with Section M1507.3.

R303.5 Opening Location Outdoor intake and exhaust openings shall be located in accordance with Sections R303.5.1 and R303.5.2.

R303.5.1 Intake Openings Mechanical and gravity outdoor air intake openings shall be located a minimum of 10-feet from any hazardous or noxious contaminant, such as vents, chimneys, plumbing vents, streets, alleys, parking lots and loading docks, except as otherwise specified in this code. Where a source of contaminant is located within 10-feet of the intake opening, such opening shall be located a minimum of 3-feet below the contaminant source.

(For the purpose of this section, the exhaust from dwelling unit toilet rooms, bathrooms, and kitchens shall not be considered as hazardous or noxious)

R303.5.2 Exhaust Openings Exhaust air shall not be directed onto walkways.

R303.7 Stairway illumination. All interior and exterior stairs shall be provided with a means to illuminate the stair, including the landings and treads. Interior stairs shall be provided with an artificial light source rated at one-foot candle located in the immediate vicinity of each landing of the stairs. Exterior stairs shall be provided with an artificial light source located in the immediate vicinity of the top landing of the stair.

Exceptions:

1. An artificial light source is not required at the top and bottom landing, provided an artificial light source is located directly over each stair section.

R303.7.1 Light activation. Where lighting outlets are installed in interior stairways, there shall be a wall switch at each floor level to control the lighting outlet where the stairway has six or more risers. The illumination of exterior stairs shall be controlled from inside the dwelling unit.

Exception:

1. Lights that are continuously illuminated or automatically controlled.

R303.8 Required glazed openings. Required glazed openings shall open directly onto a street or public alley, or a yard or court located on the same lot as the building.

R303.8.1 Sunroom Additions. Required glazed openings shall be permitted to open into sunroom additions and patio covers that abut a street, yard, or court if in excess of 40 percent of the exterior sunroom walls are open, or enclosed only by insect screening, and the ceiling height of the sunroom is not less than 7-feet.

R303.9 Required heating. When the winter design temperature in Table R301.2(1) is below 60°F, every dwelling unit shall be provided with heating facilities capable of maintaining a minimum room temperature of 68°F at a point 3 feet above the floor and 2 feet from exterior walls in all habitable rooms at the design temperature. The installation of one or more portable space heaters shall not be used to achieve compliance with this section.

SECTION R304

MINIMUM ROOM AREAS

R304.1 Minimum area. Every dwelling unit shall have at least one habitable room that shall have not less than 120 square feet of gross floor area.

R304.2 Other rooms. Other habitable rooms shall have a floor area of not less than 70 square feet.

Exception: Kitchens.

R304.3 Minimum dimensions. Habitable rooms shall not be less than 7 feet in any horizontal dimension.

Exception: Kitchens.

R304.4 Height effect on room area. Portions of a room with a sloping ceiling measuring less than 5 feet, or a furred ceiling measuring less than 7 feet from the finished floor to the finished ceiling shall not be considered as contributing to the minimum required habitable area for that room.

SECTION R305

CEILING HEIGHT

R305.1 Minimum height. Habitable rooms, hallways, bathrooms, toilet rooms, laundry rooms and portions of the basements containing these spaces shall have a ceiling height of not less than 7 feet.
(see exceptions next page)

Exceptions:

1. For rooms with sloped ceilings, at least 50 percent of the required floor area of the room must have a ceiling height of at least 7 feet and no portion of the required floor area may have a ceiling height of less than 5 feet.
2. Bathrooms shall have a minimum ceiling height of 6 feet 8 inches at the center of the front clearance area for fixtures as shown in Figure R307.1. The ceiling height above fixtures shall be such that the fixture is capable of being used for its intended purpose. A shower or tub equipped with a showerhead shall have a minimum ceiling height of 6 feet 8 inches above a minimum area 30 inches by 30 inches at the showerhead.

R305.1.1 Basements. Portions of basements that do not contain habitable space, hallways, bathrooms, toilet rooms, and laundry rooms shall have a ceiling height of not less than 6 feet, 8 inches.

Exception. Beams, girders, ducts or other obstructions may project to within 6 feet, 4 inches of the finished floor.

SECTION R307

TOILET, BATH AND SHOWER SPACES

R307.1 Space required. Fixtures shall be spaced in accordance with Figure R307.1, and in accordance with Section P2705.1.

R307.2 Bathtub and shower spaces. Bathtub and shower floors and walls above bathtubs with installed shower heads and in shower compartments shall be finished with a nonabsorbent surface. Such wall surfaces shall extend to a height of not less than 6 feet above the floor.

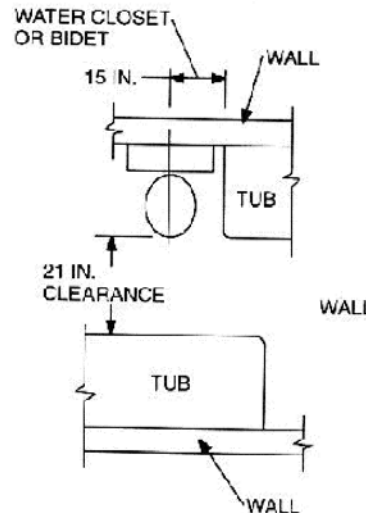
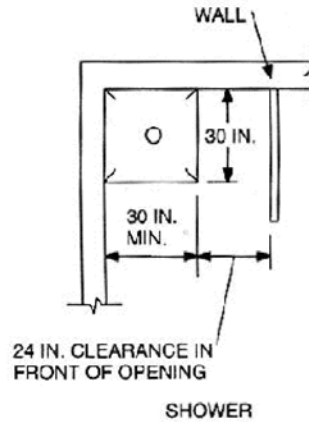
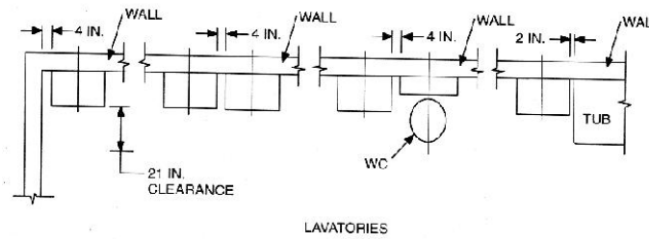

**LIGHT, VENTILATION AND HEATING
MINIMUM ROOM AREAS
CEILING HEIGHT
TOILET, BATH AND SHOWER SPACES**



City of Richmond

Department of Codes Enforcement
239 West Main Street
Richmond, KY 40475

(859) 625-6404

Monday – Friday
8:00 AM to 4:30 PM